



**SAM 010-130 DIN is a series of light weight casing axial piston motors, particularly suitable for mobile hydraulics.**

SAM 010-130 DIN is of the bent-axis type with spherical pistons. The design gives a compact motor with few moving parts, high starting torque and high operational reliability. It covers the entire displacement range 10-130 cm<sup>3</sup>/rev. with max. pressure 400 bar. The high level of reliability is due to the choice of materials, hardening methods, surface structures and the quality assured manufacturing process.

**Other advantages:**

- Corrosion free light metal-housing Smooth operation over the entire speed range
- Smooth operation over the entire speed range
- High efficiency
- Suitable for applications with high angular accelerations due to its high rotary stiffness
- Light weight
- Less heat generation due to better ability to dissipate heat through housing

## Versions, main data

Example

<b>SA</b>	<b>M</b>	-	<b>012</b>	<b>W</b>	-	<b>N</b>	-	<b>DL4</b>	-	<b>L35</b>	-	<b>s3</b>	<b>G</b>	-	<b>1</b>	<b>00</b>
Line	1		2	3		4		5		6		7	8		9	10

Line	
SA	Sunfab Aluminium

1. Type	
P	Motor

2. Displacement	
010 012 017 025 034 040 047 056 064 084 090 108 130	

3. Direction of rotation	
W	Independent

4. Shaft seal	
N	Nitrile

5. Mounting flange	
DL4	DIN 4-h (ISO 7653D)

6. Shaft	
L35	DIN 5462 / ISO 14
H35	DIN 5462 / ISO 14 Ø 8.15

7. Connection cover		010 012 017 025 034 040 047 056 064 084 090 108 130
S3	40° Threaded connection	X X X X X X X X X X X X X

8. Connection cover		010 012 017 025 034 040 047 056 064 084 090 108 130
G	ISO G*	X X X X X X X X X X X X X

9. Additional	
1	External drainage

10. Speed Sensor	
00	No Speed Sensor

SAM 010-130 DIN		010	012	017	025	034	040	047	056	064	084	090	108	130	
<b>Displacement</b>															
cm <sup>3</sup> /rev		9.6	12.6	17.0	25.4	34.2	41.2	47.1	56.7	63.5	83.6	90.7	108.0	130.0	
<b>Working pressure</b>															
bar	<i>max intermittent</i>	400	400	400	400	400	400	400	400	400	400	400	400	400	330
	<i>max continuous</i>	350	350	350	350	350	350	350	350	350	350	350	350	350	280
<b>Revolutions</b>															
rpm	<i>max intermittent</i>	3000	3000	3000	3000	3000	2500	2500	2500	2500	2000	2000	2000	2000	2000
	<i>max continuous</i>	2400	2400	2400	2400	2400	2000	2000	2000	2000	1600	1600	1600	1600	1600
	<i>min continuous</i>	300	300	300	300	300	300	300	300	300	300	300	300	300	300
<b>Max power</b>															
kW	<i>max intermittent</i>	14	18	24	36	49	57	65	78	88	93	100	120	124	124
	<i>max continuous</i>	11	14	19	29	39	46	52	62	70	74	81	96	99	99
<b>Starting torque theoretical value</b>															
Nm/bar		0.15	0.20	0.27	0.40	0.54	0.66	0.75	0.89	1.00	1.33	1.44	1.71	2.06	
<b>Moment of inertia (x 10<sup>-3</sup>)</b>															
kg m <sup>2</sup>		0.9	0.9	0.9	1.1	1.1	2.6	2.6	2.6	2.6	7.4	7.4	7.4	7.4	
<b>Max intermittent housing pressure</b>															
bar		5	5	5	5	5	5	5	5	5	5	5	5	5	
<b>Weight</b>															
kg		6.9	6.9	6.9	7.1	7.1	9.9	9.9	9.9	9.9	13.8	13.8	13.8	13.8	

Intermittent duty is defined as follows: max 6 seconds per minute, e.g. peak RPM when unloading or accelerating.

# Dimensions SAM 010-034

## Flange, shaft & connection cover

Millimeter (inch)

### DL4 ISO 7653-D

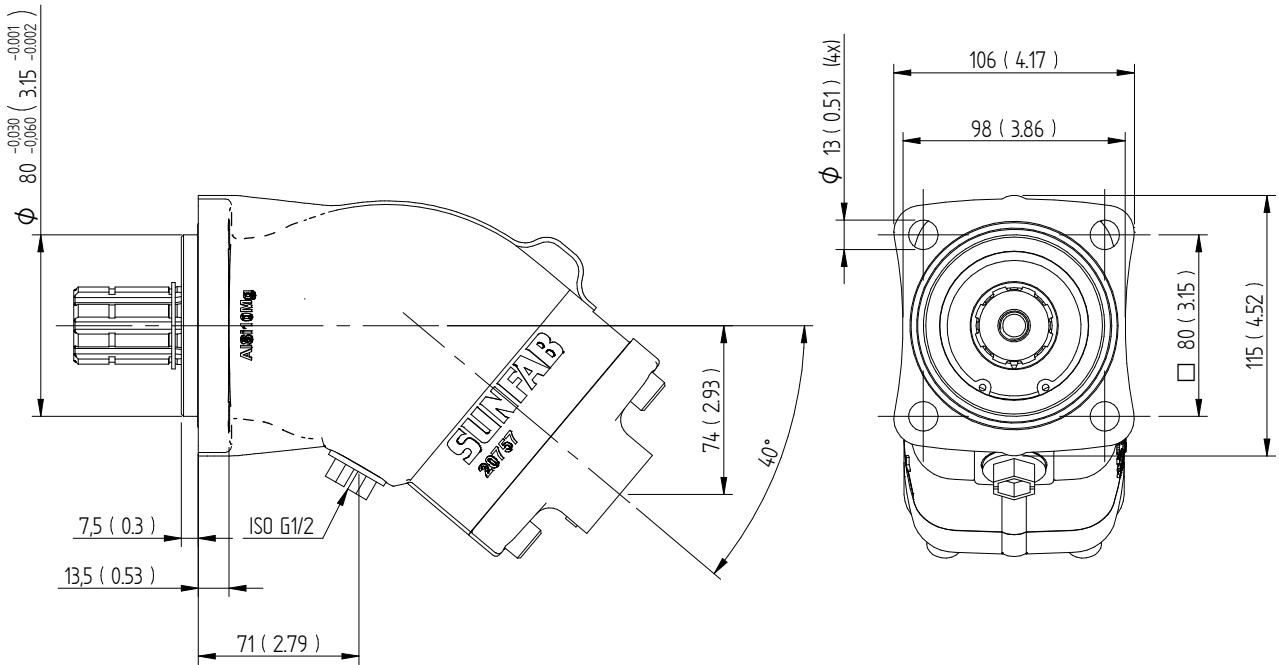

### L35 DIN 5462 / ISO 14

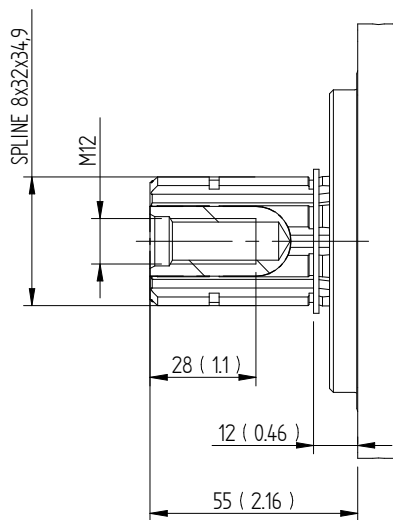

### S3G

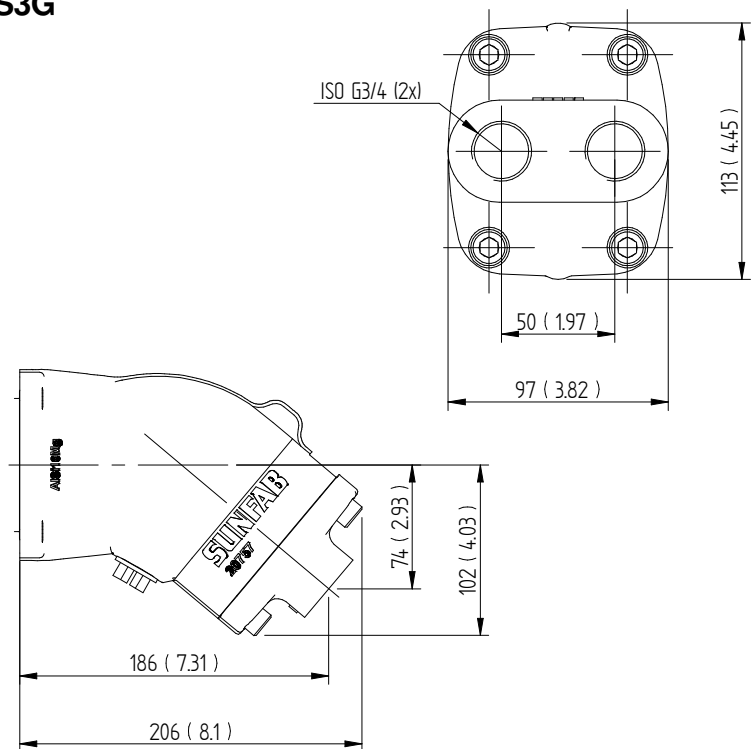

# Dimensions SAM 040-064

## Flange, shaft & connection cover

Millimeter (inch)

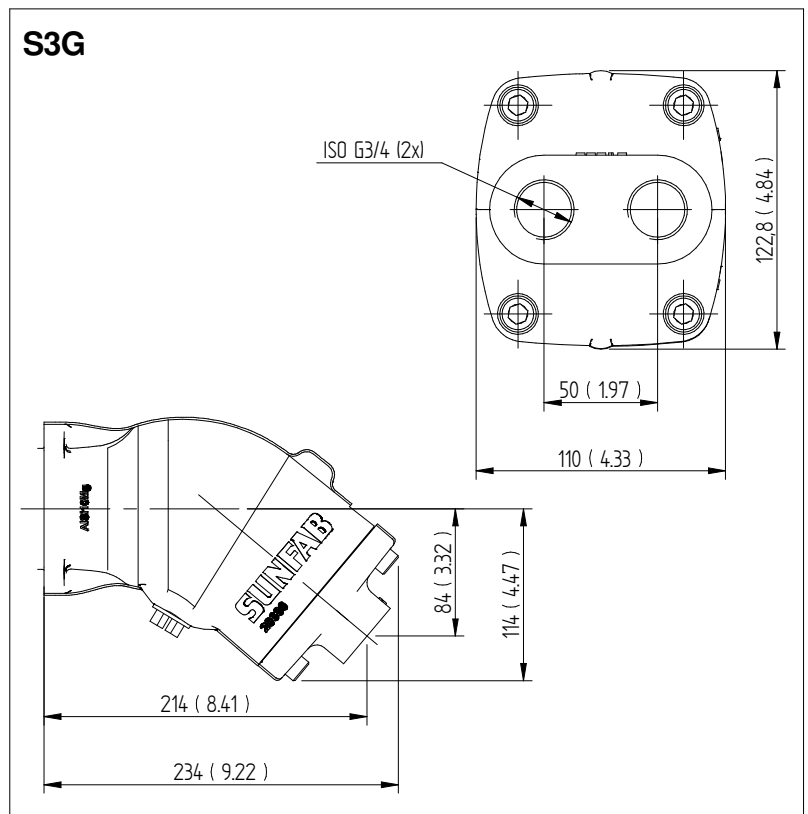
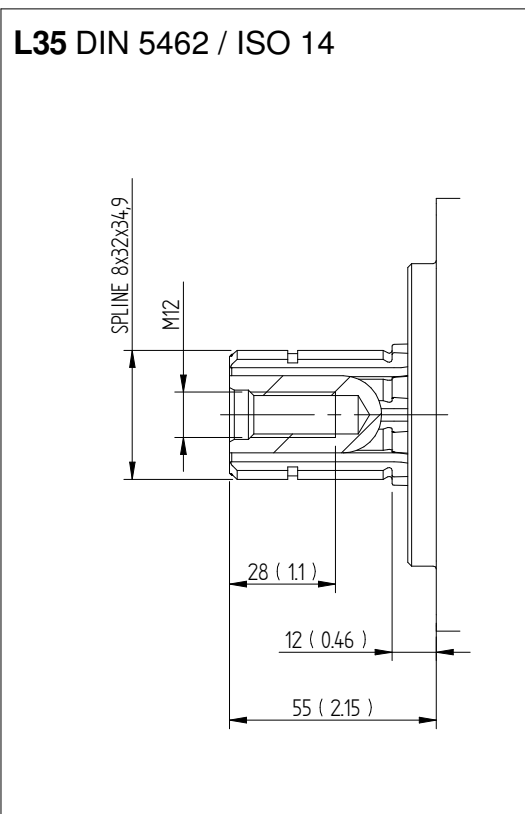
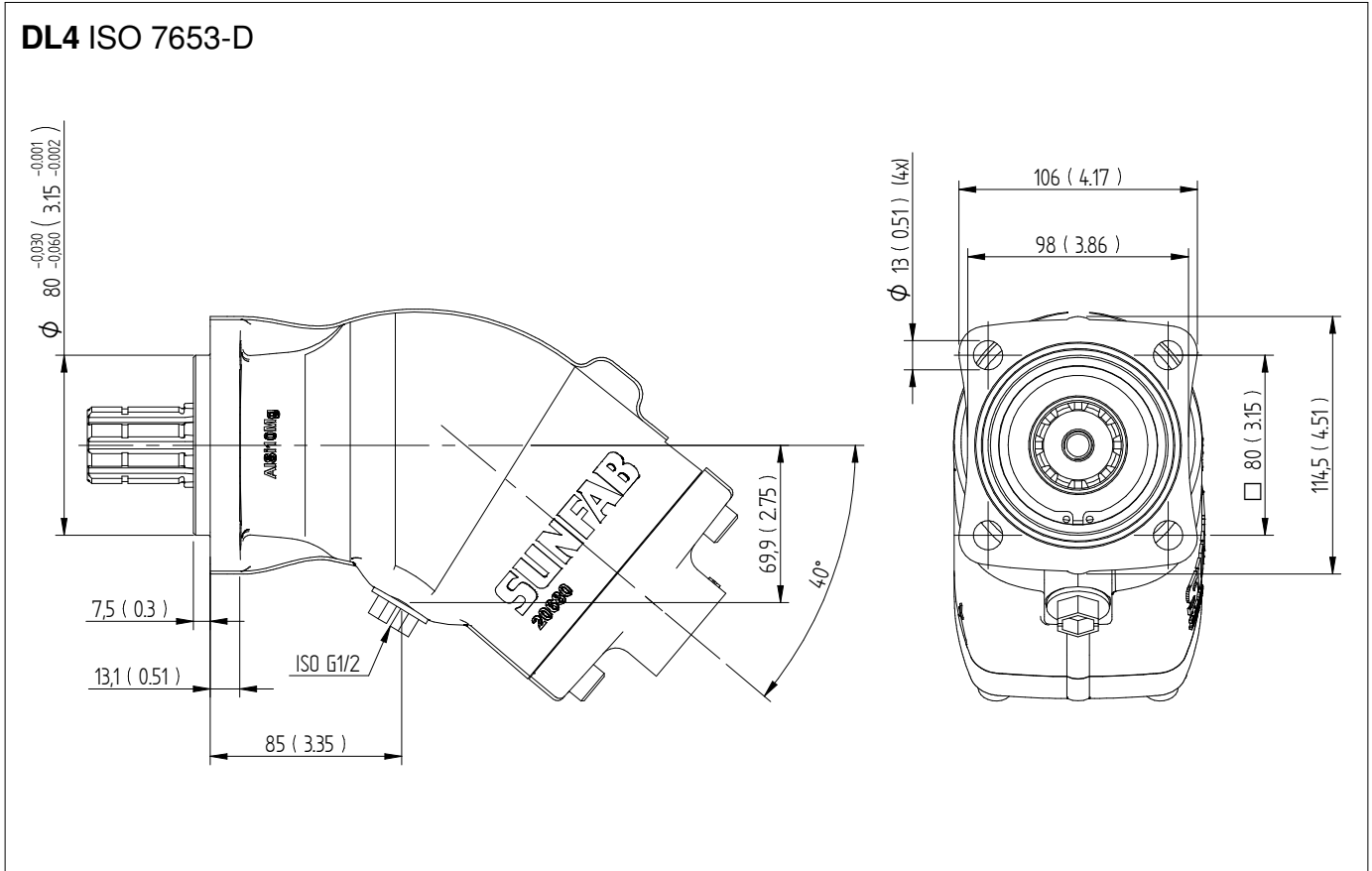

# Dimensions SAM 084-130

## Flange, shaft & connection cover

Millimeter (inch)

### DL4 ISO 7653-D

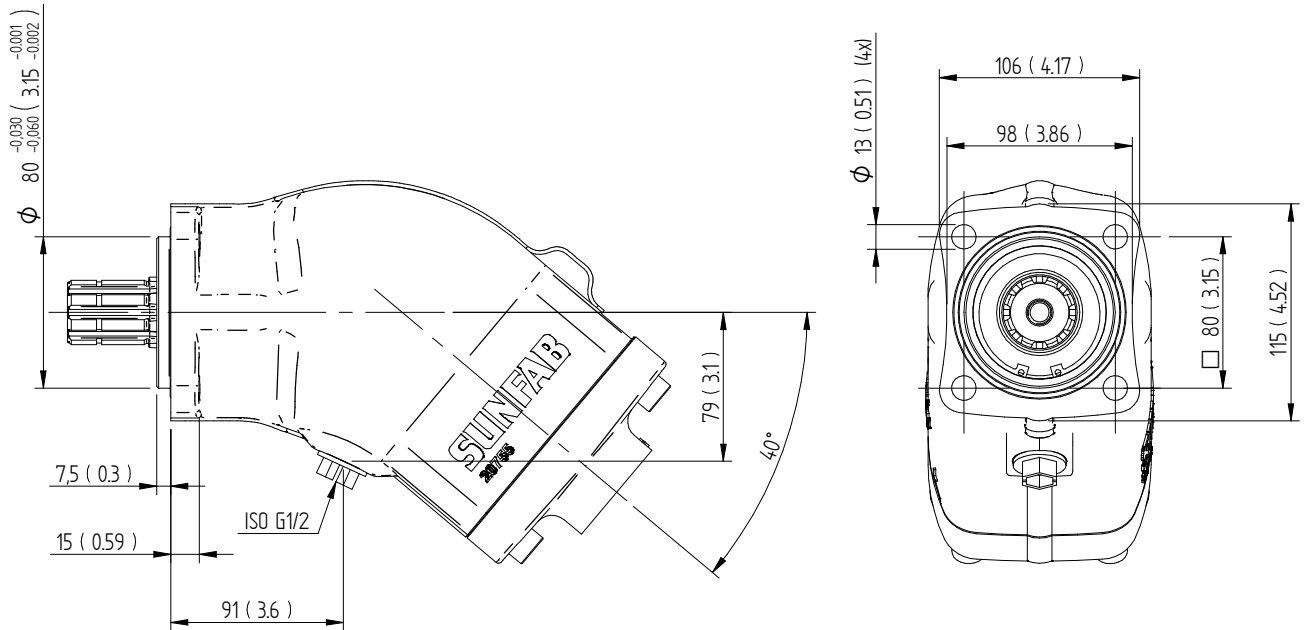

### L35 DIN 5462 / ISO 14

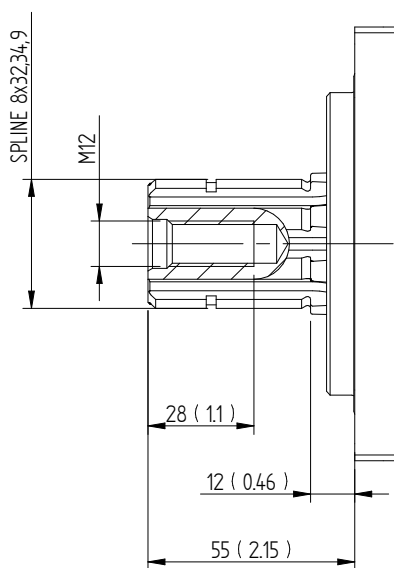

### S3G

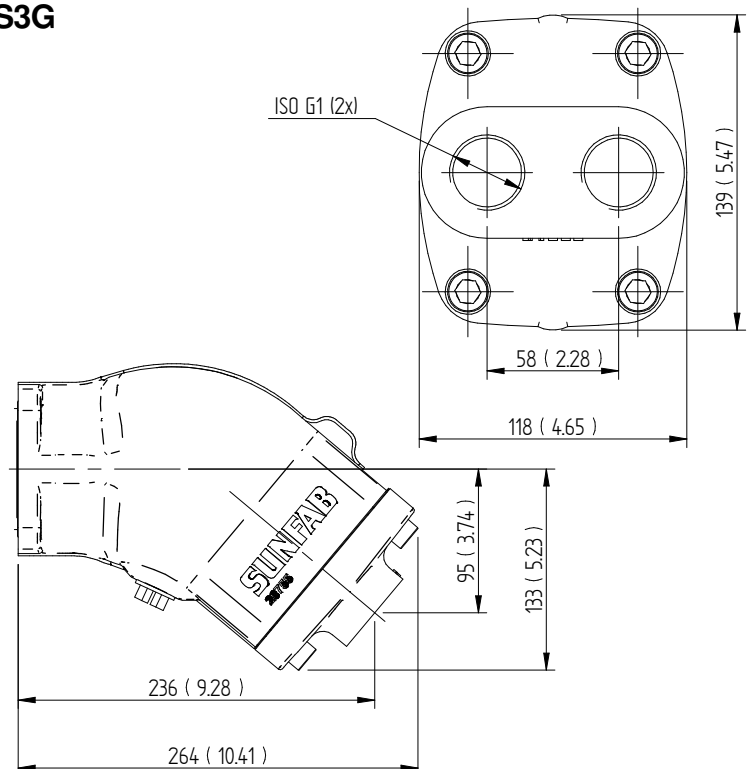

## Shaft loads

The service life of the motor largely depends on the service life of the bearings. These are affected by the operating conditions such as speed, pressure, oil viscosity and degree of purification.

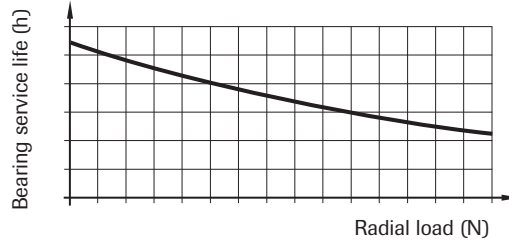
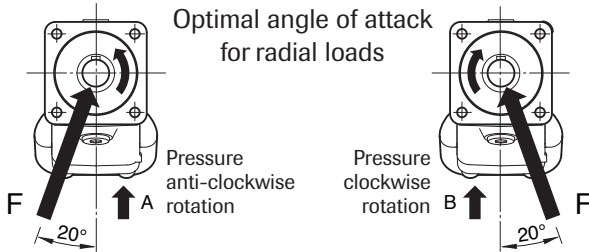

External loading of the shaft, its size, direction and location also affect the service life of the bearings.

If a calculation of bearing service life is required for special applications, contact Sunfab Hydraulics.

## Installation

The motor housing is filled with oil to at least 50% of the volume before start up. The drainage hose is connected to the drainage outlet positioned highest on the motor. The other end is connected below the oil level in the oil tank.

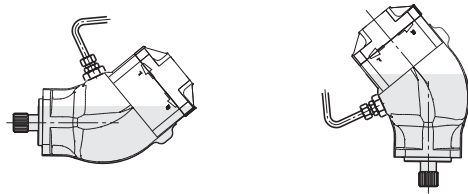

## Hydraulic fluids

High performance oil meeting the specifications of ISO type HM, DIN 51524-2HLP or better must be used. Min. viscosity 10 cSt is required to guarantee lubrication. Ideal viscosity is 20 - 40 cSt.

## Pipe dimensions

The recommended flow velocity in the pressure line is max 7 m/sec.

## Filtering

Cleanliness ISO norm 4406, code 16/13 is recommended.

## Useful formulae

Required flow rate  $Q = \frac{D \times n}{1000 \times \eta_v}$  litres/min.

Speed  $n = \frac{Q \times 1000 \times \eta_v}{D}$  RPM

Torque  $M = \frac{D \times \Delta p \times \eta_{hm}}{6.3}$  Nm

Power  $P = \frac{Q \times \Delta p \times \eta_t}{60}$  kW

D = displacement, cm<sup>3</sup>/rev

n = revolutions, rev/min

P = power, kW

Q = flow, litre/min

$\eta_v$  = volumetric efficiency

$\eta_{hm}$  = hydromechanical efficiency

$\eta_t$  = total efficiency =  $\eta_v \times \eta_{hm}$

M = torque, Nm

$\Delta p$  = pressure difference between inlet and outlet on the hydraulic motor, MPa



**WARNING!**

When the motor is in use:

1. Do not touch the pressure pipe
2. Watch out for rotating parts
3. The motor and pipes can reach high temperatures

Sunfab reserves the right to make changes in design and dimensions without notice. Printing and typesetting errors reserved.

© Copyright 2023 Sunfab Hydraulics AB. All Rights Reserved.