



ANTI-CAVITATION VALVE



Anti-cavitation valve for Sunfab's hydraulic motor SCM

Sunfab's anti-cavitation valve is used to minimise the risk of cavitation damage in connection with insufficient inlet pressure.

This can occur, for example, in applications with a relatively large rotating mass with a long run-down time (e.g. fan operations). The hydraulic motor must have a defined direction of rotation when using Sunfab's anti-cavitation valve. The valve can be adapted to both left and right rotation.

Function:

A check valve between the pressure and return ports opens to ensure a flow of oil to the motor if the inlet pressure to the motor becomes too low. It is therefore important to have a specific back pressure on the return line, which if necessary can be created by means of a back-pressure valve.

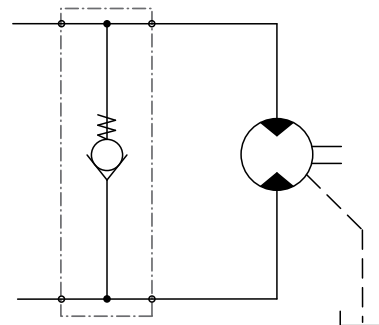

For motor SCM

		010-034 S3	010-034 K3	040-064	084-130
Max. continuous pressure	bar	350	350	350	350
Max. intermittent pressure	bar	400	400	400	400
Weight	kg	1.6	1.7	3.9	3.4



Dimensions anti-cavitation valve

Valve for SCM 010-034 S3
Part No. 91199

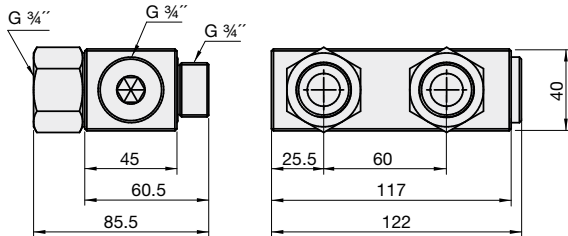

Only suits S3-cover

Valve for SCM 010-034 K3
Part No. 91024

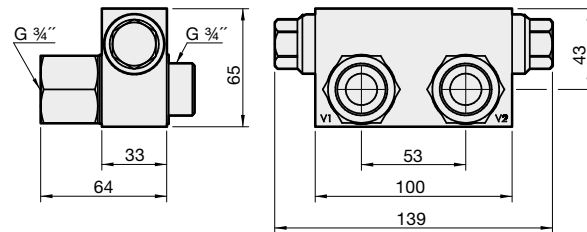

Only suits K3-cover

Valve for SCM 040-064
Part No. 91025

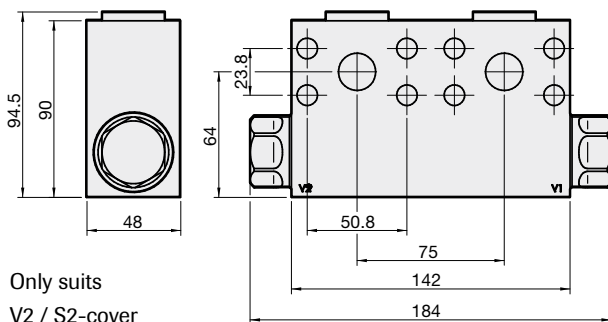

Only suits
V2 / S2-cover

Valve for SCM 084-130
Part No. 91026

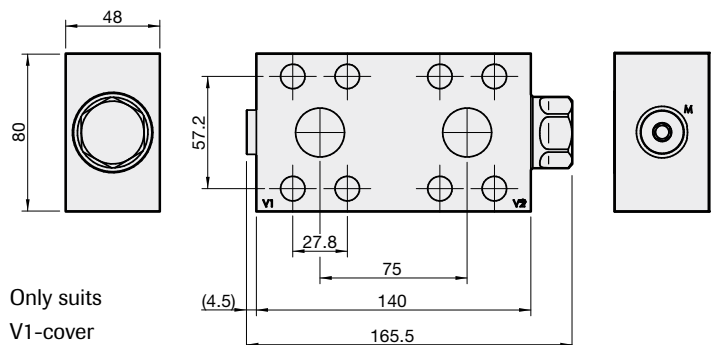

Only suits
V1-cover

Type SCM	010-034 S3	010-034 K3	040-064	084-130
Valve part no.	91199	91024	91025	91026
Metric - Bolt kit part no.	-	-	50854	50855
UNC - Bolt kit part no.	-	-	50982	51030
Min-max flange height [mm]	-	-	16-21	21-25
Flange kit part no.	-	-	50857	50858
Flange thread dim.	-	-	G 3/4"	G 1"

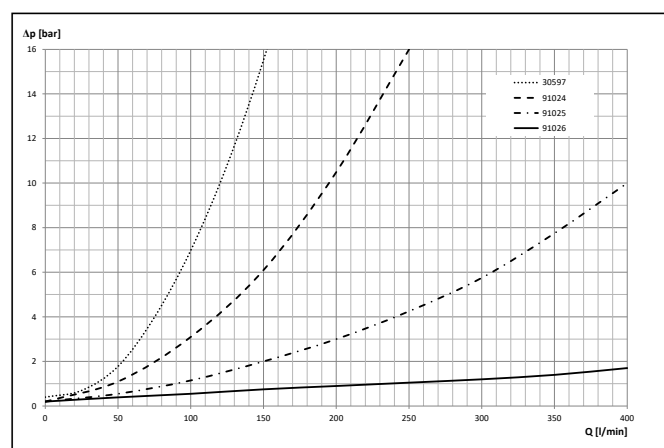

Valve opening pressure 0,3 bar

Sunfab reserves the right to make changes in design and dimensions without notice. Printing and typesetting errors reserved.
© Copyright 2021 Sunfab Hydraulics AB. All Rights Reserved.